

Instrument High-Voltage Capacitors

IHC series

IHC-10, IHC-35, IHC-110, IHC-220, and IHC-330 models

User's Manual

Contents

INTRODUCTION	3
1 SAFETY REQUIREMENTS	3
2 GENERAL INFORMATION AND OPERATION PRINCIPLE.....	4
2.1 PURPOSE AND FIELDS OF APPLICATION	4
2.2 OPERATING CONDITIONS.....	4
2.3 CONTENTS OF IHC DELIVERY PACKAGE	4
2.4 SPECIFICATIONS.....	4
2.5 DESIGN AND OPERATION.....	5
3 PREPARING FOR OPERATION.....	8
3.1 OPERATING RESTRICTIONS.....	8
3.2 UNPACKING	8
3.3 PREPARING FOR OPERATION.....	8
4 OPERATION.....	8
5 USER MAINTENANCE	9
6 STORAGE	10
7 TRANSPORTATION	10
8 MARKING AND SEALING	10
9 WARRANTY	11
10 PACKING FORM	13
11 ACCEPTANCE FORM	13
12 WARRANTY CLAIM.....	14
13 CALIBRATION PROCEDURE	14

Introduction

This User's manual covers Instrument-class High-Voltage Capacitors of IHC series (the IHC below). The User's Manual describes its operation, maintenance, transportation, storage and manufacturer's warranty conditions. The UM also includes information about the calibration procedure, packing form and acceptance form.

1 Safety requirements

1.1 When putting the IHC into operation and during operation, "Interbranch Rules for Labor Safety (Safety Rules) When Operating Electrical Systems" (M, "Energoatomizdat") must be observed.

1.2 When a voltage of 650V (or greater) is applied to the IHC, safety grounding terminals must be connected to the ground in any case.

1.3 Clamp "ground" terminal must provide secure fastening and reliable electrical connection between the IHC and flexible grounding cable.

1.4 Dielectric strength of IHC's insulation provides for withstanding test voltage of (50 ± 1) Hz frequency and of values indicated in Table 3 of this Manual. Test voltage is applied between the high-voltage (HV) terminal and low voltage (LV) terminal connected to the "Ground" terminal.

1.5 Resistance of insulation between the insulated electrical circuits and IHC's body (case) must be at least 100 MOhm.

1.6 When testing the IHC, current national and corporate Safety Rules for high-voltage systems (operating voltage over 1000V) must be observed.

1.7 Before applying high voltage to the HV electrode, the case of high-voltage capacitor must be properly grounded and output terminal of the IHC must be connected to the ground by the short-circuit cable or to the load with 10 kOhm impedance (but no more).

1.8 Working on high-voltage capacitors in the electrical circuits with operating voltage over 200V is only permitted in the presence of other persons.

1.9 IHC shall only be operated or tested by the technical staff familiar with this User's Manual and all operation documentation for the instruments, devices, tools and any other equipment used during operation or testing as well as with Electrical Safety Rules for high-voltage systems (operating voltage over 1000V).

1.10 Electricians operating with IHC shall have electrical safety qualification level IV (but no less) that permits to operate high-voltage systems with operating voltage

over 1000V. If measurements are carried out by a group of electricians, the operation manager shall have electrical safety qualification level IV (but no less), other employees are permitted to have electrical safety qualification level III (but no less).

1.11 Before applying high voltage to the high-voltage electrode (HV electrode) U1 (see Fig. 2), the IHC case must be properly grounded and output terminal X1 must be connected to the ground by the short-circuit cable K1 or to the load with 10 kOhm impedance (but no more).

2 General information and operation principle

2.1 Purpose and fields of application

The IHC is designed to fit various measurement equipment such as VT testers, voltage dividers, testers of high-voltage insulation (that can determine capacitance and tangent of loss angle) and, being used as part of test system, to test (calibrate) VTs of 0.05 accuracy class or less accurate.

2.2 Operating conditions

Environmental conditions for the IHC shall be as follows:

- Ambient temperature, °C -10 to +40;
- Relative humidity at 25 °C, no more than, % 80;
- Atmospheric pressure, kPa (mm Hg) 84–106.7 (630–800);
- Nominal AC frequency, Hz 50 ± 2;
- Operating voltage, kV 10–330/√3.

2.3 Contents of IHC delivery package

Delivery package is specified in Table 1.

Table 1

Name and description	Qty
Instrument High-Voltage Capacitor IHC	1
Short Circuit cable (K1)	1
User's Manual	1
Calibration procedure description	1
Calibration Certificate	1*
Packaging box	1
High Voltage Corona-free cable (K4, N 25/10)	1*

* Provided at customer's option

2.4 Specifications

2.4.1 The IHC comes in five design versions with respect to metrological and tech-

nical characteristics specified in Tables 2 and 3.

Table 2

Metrological and technical characteristics common to all IHC models

Parameter	Value
Rated (nominal) capacitance, pF	46, 48, 50, 52, 96, 98, 100, 102
Permissible deviation from nominal value, pF	± 2.5
Limits of permissible relative error of capacitance, %	± 0.1 или ± 0.05
Tangent of loss angle, no more	$0.5 \cdot 10^{-4}$
Operating conditions: - Ambient temperature, °C - Atmospheric pressure, kPa (mm Hg) - Relative humidity at 25 °C, no more than, %	-10 ... +40 84–106.7 (630–800) 80
Apparent charge of a partial discharge, pC, or less	5
Capacitance-vs-voltage coefficient, %, or less	0.01
Time to failure, h	8000
Mean life time, years	8

Table 3

Model	Rated voltage, kV	Test voltage (applied for 5 min), kV	Temperature coefficient of capacitance 10^{-6} K^{-1}	Excessive pressure of SF ₆ MPa				Overall dimensions (height × diameter), mm	Weight, kg (or less)
				MPa		at (kgf/cm ²)			
				nominal	minimal	nominal	minimal		
IHC-10	10	22	160	0.1	0.0	1.02	0.00	240x150	4
IHC-35	35	60	60	0.3	0.2	3.06	2.04	490x380	11
IHC-110	110/√3	100	120	0.3	0.2	3.06	2.04	550x380	12
IHC-220	220/√3	183	40	0.3	0.2	3.06	2.04	1165x505	45
IHC-330	330/√3	267	100	0.35	0.25	3.57	2.55	1400x550	75

2.4.2 Rated value of capacitance measured with permissible limits of error $\delta = \pm 0.1$ % or $\delta = \pm 0.05$ % is specified in User's manual (section 11). The rated value of capacitance rounded to 3 significant digits is indicated on the nameplate located on the IHC case.

2.4. The IHC is considered set for stable operation on finishing the commissioning procedure.

2.5 Design and operation

2.5.1 The IHC contains cylindrical electrodes inside the shielded case 1 (see Fig. 1), hollow cylindrical polymeric insulator 2 and basement 3. The ring shaped handle 4 is

located near the lower flange of the polymeric insulator 2. The corona shield 5 and winged HV cable fixing nut are located at the top of the insulator. The pressure gauge (manometer) 6 that indicates gas pressure inside the IHC is placed in the basement window as shown in the figure (IHC-10 capacitors are not equipped with manometers). Grounding cable is fixed by the winged nut 7 located on the basement. Low voltage (LV) lead terminated by coaxial connector (BNC 50 Ohm) is placed on the IHC basement 3.

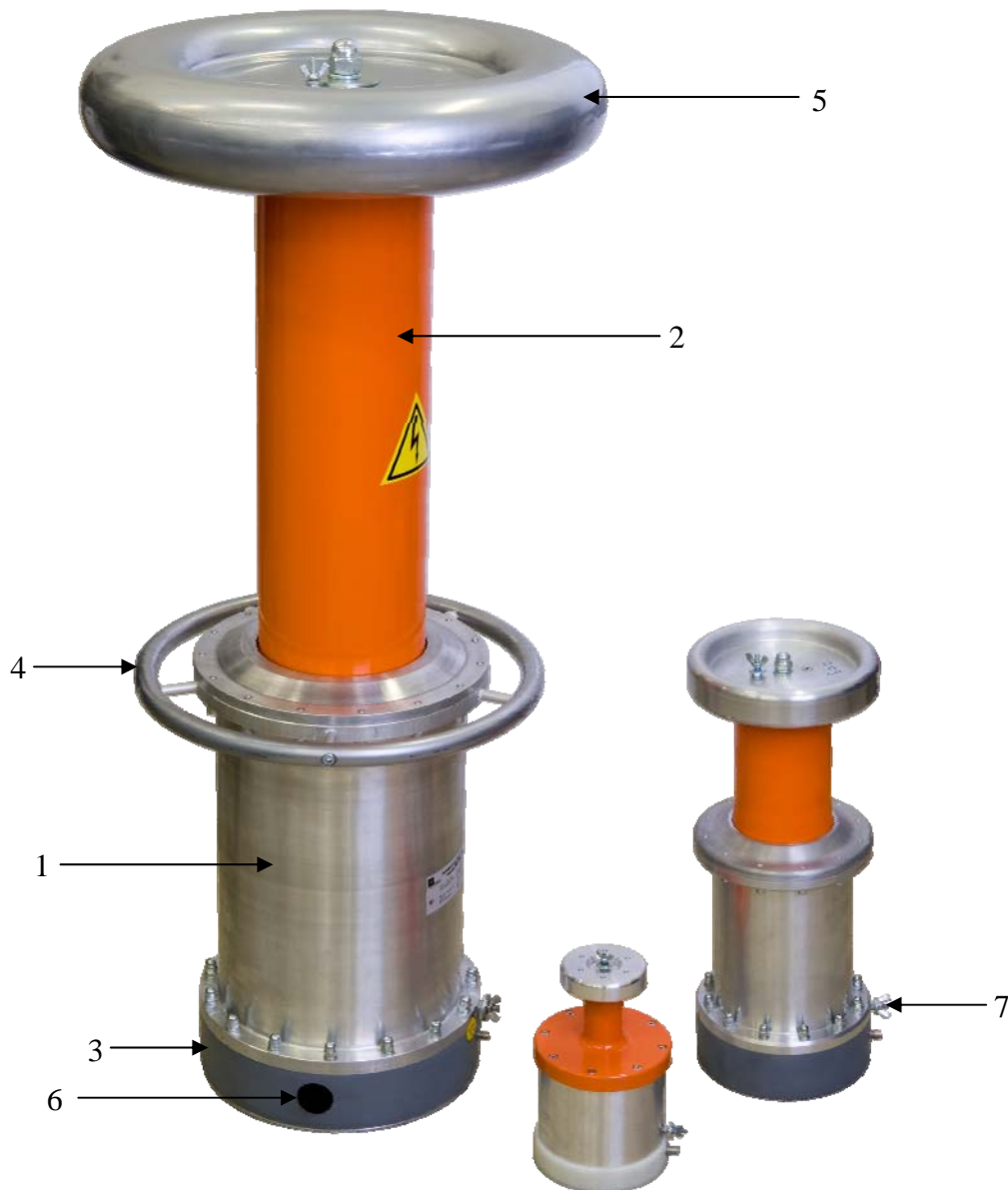

Fig. 1. General view of IHCs:

1 — body (case); 2 — polymeric insulator 3 — basement; 4 — ring shaped handle;
5 — corona shield, 6 — manometer, 7 — ground terminal

2.5.2 Schematic diagram of IHC electrical circuit is shown in Fig. 2.

Capacitor C1 represents a coaxial gas gap filled with insulation gas (sulfur hexafluoride) under pressure. The capacitor is formed by the inner cylindrical HV electrode and outer hollow cylinder. Capacitor C2 is formed by the above-mentioned hollow cyl-

inner and outer case connected to the ground. Stray current passes through capacitor C3 formed by HV electrode - air - earth. Stray current passes through capacitor C4 formed by HV electrode - insulator - IHC case.

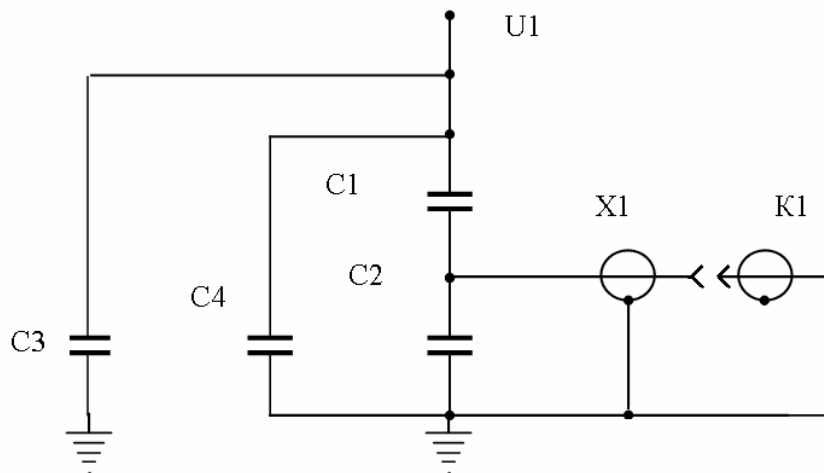

Fig. 2. Equivalent circuit of the IHC:

C1 — high voltage capacitor, C2 — low voltage capacitor, C3 — "HV electrode - air - earth" capacitor (parasitic capacitance), C4 — "HV electrode - insulator - ground" capacitor (parasitic capacitance), X1 — signal (measurement) electrode (LV), U1 — HV electrode, K1 — short circuit cable

2.5.3. Reference standards of capacitance, capacitors of IHC series, are capable of maintaining reported values of capacitance with high stability while providing small loss tangent values (less than $5 \cdot 10^{-5}$) along with small level of partial discharge (PD) (5 pC or less). These features make it possible to use IHCs as reference capacitors in measurement bridges, design high-precision voltage dividers or reference standards of loss tangent on the basis of IHCs and use them in systems measuring level of partial discharge.

2.5.4. When using the IHC as a reference capacitor for $\text{tg}\delta$ measurements, connect its HV terminal in parallel to the insulator to be tested, and its LV terminal - to the bridge terminal.

When the IHC is used as a HV arm of the voltage divider, its LV terminal is connected to the LV arm of the divider.

Due to the special design of the protection shield, external fields do not essentially affect the values of reference capacitance.

The IHC does not require special adjustment.

3 Preparing for operation

3.1 Operating restrictions

3.1.1 If the IHC has been moved from a cold environment (with ambient temperature below 0° C) into a warm one, it shall be left to stand for at least 4 hours at room temperature before applying power, to make sure that no condensation remains inside.

Caution!

The IHC shall not be used under the ingress of moisture inside its body or on the insulator.

3.1.2 Gas pressure in the IHC must be no less than the values specified in Table 3 for the corresponding model.

3.1.3 The surface of the insulator shall be kept clean. The insulator shall only be cleaned with a clean cotton cloth wetted with ethyl alcohol.

3.2 Unpacking

Check that the delivery package contains all parts specified in the Supply Agreement. Check that the manufacturer's seal is intact. Should anything in the package be found damaged, contact the supplier immediately. The delivery package is specified in Table 1.

3.3 Preparing for operation

3.3.1 Measuring equipment must be properly grounded before work. Ground terminals must be connected to the grounding circuit prior to making any other electrical connection and disconnected after disconnecting all other circuits. Use the manufacturer-supplied measurement cables only. Inspect the cables. Ensure all joints are made properly to avoid excessively high resistance.

4 Operation

4.1 Connecting to measuring circuit

Caution!

To avoid electric shock, you must connect (disconnect) the IHC to the measured circuits when they are de-energized (according to safety regulations in force).

Grounding terminal of the device under test and grounding terminal of the IHC must be directly connected together by a copper cable with cross-section of 4mm as a minimum. The cable is connected to the grounding circuit.

Connect low voltage cables to the IHC first, before the high voltage cable is connected to it.

LV terminal of the IHC is connected to the LV terminal of the device under test or to an arm of the HV measuring bridge via K1 cable.

4.2 Connecting to high test voltage.

Before applying high voltage (50Hz), ensure that safety requirements are met, **gas pressure** agrees with the rating specified in Table 3 and high voltage cannot take the value greater than **120 %** of the nominal voltage specified for the corresponding IHC model (see Table 3). **You must not instantaneously apply the full value of nominal voltage ("with one stroke")**. IHC model is specified in the nameplate located on the body.

It is strongly recommended to connect HV terminal of the IHC to HV terminal of the device under test via manufacturer-supplied corona-free HV cable K4 (for IHC-10 use the insulated cable included in the delivery package).

5 User Maintenance

5.1 Maintenance is the care and servicing that the user provides for keeping the equipment operational over its life cycle.

5.2 Every maintenance operation shall meet safety requirements described in Sections 1 and 3.3.2.

5.3 Routine maintenance includes the following operations:

Operation	Interval
Measuring strength of insulation	once a year
Wiping the connector (BNC 50 Ohm) with alcohol	no less than once a month
Checking gas pressure	no less than once a month and prior to each test
Cleaning the oxidized contacts and checking the reliability of their fixing	once a year

5.4 Troubleshooting

№	Fault	How to solve the problem
1	Pressure is lower than acceptable (minimal values are shown in Table 3)	Gas leakage; the device shall be forwarded to the manufacturer
2	Distorted signal or no signal from measurement (BNC 50 Ohm) connector	The device shall be forwarded to the manufacturer

Note:

When monitoring pressure of insulation gas, please take into account that the manometer installed inside the IHC body is scaled in kgf/cm^2 (see Table 3 of this Manual).

6 Storage

6.1 The IHC shall be stored in the manufacturer's package, in a heated storeroom.

6.2 Storage conditions in the manufacturer's package: ambient temperature from 0 to 40°C, relative humidity < 80 % at 35 °C.

Storage conditions without the package: ambient temperature from 5 to 35° C, relative humidity 80 % at 25 °C

6.3 The storeroom should be free from current-conductive dust, acid or alkali fumes and other aggressive substances.

7 Transportation

7.1 The Device should be transported packed in the manufacturer's box. The Device can be transported in any enclosed vehicle including air-tight heated plane cargo compartment.

Ambient conditions allowed during transportation: ambient temperature: from - 20 °C to +55 °C; relative humidity < 90 % at 25 °C.

8 Marking and sealing

8.1 The IHC's nameplate bears:

- Manufacturer's name and trademark
- Serial number
- Nominal voltage, test voltage and nominal frequency values
- Actual value of capacitance, value of loss tangent
- Nominal pressure SF₆
- Date of manufacture
- Sign of Type Approval Certificate

The template is shown below:

INSTRUMENT-CLASS HIGH-VOLTAGE CAPACITOR			
IHC- , N _____			
U nom =	kV	U test =	kV Nom. frequency 50 Hz
C=_____ pF, tgδ < 5·10 ⁻⁵			
Nom. excessive pressure (SF ₆)		MPa =	at
Date of manufacture: ____/20____			

High-voltage and low-voltage terminals are marked correspondingly. "Ground" terminal is marked by "ground" symbol according to IEC 61010-1.

8.2 Side and face walls of the transportation box bear handling symbols: "Fragile", "Keep dry" and "Top".

8.3 Seal label is stuck on the joint between parts of the IHC body.

After opening the IHC for repair, the seal should be reinstalled by the authorized Service Companies only.

9 Warranty

9.1 The warranty terms and conditions listed below comply with applicable consumer protection laws of the Russian Federation.

9.2 All products of Mars-Energo are warranted against defects in manufacture or material **for a period of 18 (eighteen) months** from the date of purchase from Mars-Energo. Equipment believed to be defective may be sent within the warranty period to Mars-Energo for inspection (Warranty Claim enclosed, transportation prepaid). If the inspection by Mars-Energo confirms that the product is defective, it will be repaired or replaced (at Mars-Energo's option) at no charge, within the underlisted limitations (paragraph 9.4), and returned prepaid to the location specified in the buyer's Warranty Claim. All replaced parts become the property of Mars-Energo.

Conditions

9.3 In the event of any Device's failure or defect in manufacture or material during the warranty period (provided that the transportation, storage and operating conditions outlined in this Manual are fulfilled), send the Device to Mars-Energo along with the sales invoice or other proof of Device's ownership and date of purchase. If the documents outlined in the previous section are absent, the warranty period is calculated from the date of Device manufacture.

Mars-Energo retains the right to reject a warranty claim, if the documents listed in the previous section are filled out incompletely, incorrectly or illegibly. This warranty will not be applicable for the Devices whose serial number has been altered, removed or made illegible.

This warranty will not be applicable for damages to your Device caused during shipment to and from Mars-Energo location.

This warranty will not be applicable:

- 1) For parts requiring regular maintenance or replacement due to natural wear;
- 2) For consumable parts (parts, the nature of which is to become worn or depleted with use, such as batteries);
- 3) For damages to the Device caused by:
 - a) Any use other than correct use described in the User manual including:

- Handling the Device resulting in mechanical damages, cosmetic defects, Device modification, or damages to the LCD;
 - Damages caused by incorrect installation;
 - Damages caused by any maintenance other than correct maintenance described in the User manual;
 - Damages caused by installation and use inconsistent with the technical and safety standards in force in the country where the Device has been installed and used;
- b) Damages caused by computer virus infection or by use of software not supplied by Mars-Energo, or damages caused by incorrect software installation;
- c) Damages caused by condition or defects of a system or its elements with which or as part of which the Device was used, excluding the other Mars-Energo products intended for use with the Device;
- d) Damages caused by accessories or ancillary equipment not made or authorized by Mars-Energo with respect to their type, condition or characteristics;
- e) Damages caused by repairs or attempts to repair the Device executed by an unauthorized person or company;
- f) Damages caused by adjustments or modifications made to the Device without prior written consent of Mars-Energo;
- g) Damages caused by negligent handling;
- h) Damages caused by accidents, fire, ingress of liquids, chemicals or other materials, flood, vibration, heat, improper ventilation, variations of supply voltage, improper power supply or input voltage, electrostatic discharge including lightning, or any other impacts or external actions beyond the reasonable control of OOO Mars-Energo and not covered by the technical documentation for the Device.

The present warranty only covers hardware failures. This warranty does not cover failures of software (produced either by OOO Mars-Energo or by other manufacturers), which are the subject of express or implied end user license agreements, separate warranties, or exclusions.

9.4 OOO Mars-Energo establishes the lifetime for the products outlined above (excluding the batteries) of 10 (ten) years from the date of purchase from OOO Mars-Energo. Warranty period for the batteries is 2 (two) years from the date of purchase from OOO Mars-Energo. *Please note that warranty period and lifetime differ from each other.*

Manufacturer's address for warranty claims follows:

Mars-Energo

V.O. 13 Line, 6 - 8, office 41H,

St. Petersburg, Russia,

199034

Tel: +7 (812) 331-87-36

Tel./Fax: +7 (812) 327-21-11

10 Packing Form

IHC- _____ ser.N _____

The aforesaid equipment has been packed by Mars-Energo in compliance with the Technical Requirements in force.

Packer signature: _____ (*Initials and Name*)

Date: _____

11 Acceptance Form

IHC- _____ ser. N _____

The aforesaid equipment has been manufactured in compliance with Technical Specifications TS 4225-043-85487191–2011 and conforms to the Technical Requirements in force.

Head of Quality Control Department _____ (*Initials and Name*)

Corporate seal

Date _____

Actual value of capacitance: _____ pF

Loss tangent: _____

Date of sale _____

Corporate Seal _____ (*Initials and Name*)

12 Warranty Claim

In the event of any Device's failure or defect in manufacture or material during the warranty period (provided that the transportation, storage and operating conditions outlined in this Manual are fulfilled), send the Device to Mars-Energo along with the Warranty Claim containing the following information:

- Device's Model and Serial number; Date of manufacture; Date of putting the Device into operation;
- Condition of the manufacturer's seals (in place, destroyed, absent);
- Description of the failure or defect;
- Customer's address and contact phone number.

13 Calibration Procedure

IHC-_____ serial N_____

Device's calibration procedure shall be carried out in compliance with the calibration methods established by D.I. Mendeleev Institute for Metrology (VNIIM, Saint-Petersburg, Russia). The Device undergoes primary post-manufacture calibration, and then it is calibrated after each repair. Regular calibration is performed during operation. A period of two calendar years is considered maximum time between calibrations.

Date of Calibration	Type of Calibration	Calibration results	Calibrator's Signature